

## Overvoltage Protection for 2-Series and 3-Series Cell Li-Ion Batteries

Check for

 Samples: [bq294502](#), [bq294504](#), [bq294512](#), [bq294515](#), [bq294522](#), [bq294524](#), [bq294532](#), [bq294562](#), [bq294572](#), [bq294582](#), [bq294592](#)

### FEATURES

- 2-Series and 3-Series Cell Monitor for Secondary Protection
- Fixed Programmable Delay Timer
- Fixed OVP Threshold:
  - bq294502 = 4.35 V with 4-s Delay Timer
  - bq294504 = 4.35 V with 6.5-s Delay Timer
  - bq294512 = 4.40 V with 4-s Delay Timer
  - bq294515 = 4.425 V with 4-s Delay Timer
  - bq294522 = 4.45 V with 4-s Delay Timer
  - bq294524 = 4.45 V with 6.5-s Delay Timer
  - bq294532 = 4.50 V with 4-s Delay Timer
  - bq294562 = 4.25 V with 4-s Delay Timer
  - bq294572 = 4.00 V with 4-s Delay Timer
  - bq294582 = 4.225 V with 4-s Delay Timer
  - bq294584 = 4.225 V with 6.5-s Delay Timer
  - bq294592 = 4.30 V with 4-s Delay Timer
- High-Accuracy Overvoltage Protection:
  - ± 10 mV

- Low Power Consumption  $I_{CC} = 1 \mu A$   
( $V_{CELL(ALL)} < V_{PROTECT}$ )
- Low leakage current per cell input < 100 nA
- Small package footprint
  - 6-pin SON

### APPLICATIONS

- 2<sup>nd</sup>-Level Protection in Li-Ion Battery Packs in:
  - Tablets
  - Slates
  - Power Tools
  - Notebook Computers
  - Portable Equipment and Instrumentation

### DESCRIPTION

The bq2945xy family of products is a secondary level voltage monitor and protector for Li-Ion battery pack systems. Each cell is monitored independently for an overvoltage condition. Based on the configuration, an output is triggered after a fixed delay if any one of the two or three cells has an overvoltage condition. This output will be triggered into a high state after an overvoltage condition has satisfied the specified delay timer.

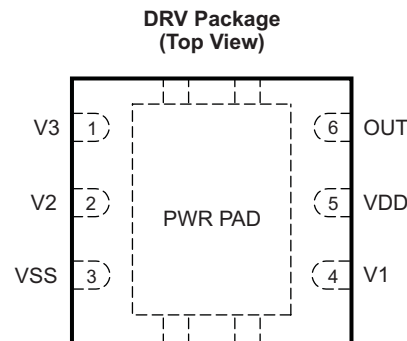

Please be aware that an important notice concerning availability, standard warranty, and use in critical applications of Texas Instruments semiconductor products and disclaimers thereto appears at the end of this data sheet.



These devices have limited built-in ESD protection. The leads should be shorted together or the device placed in conductive foam during storage or handling to prevent electrostatic damage to the MOS gates.

### ORDERING INFORMATION<sup>(1)</sup>

T <sub>A</sub>	PART NUMBER	PACKAGE	PACKAGE DESIGNATOR	OVP (V)	DELAY TIME (S)	TAPE AND REEL (LARGE)	TAPE AND REEL (SMALL)
-40°C to 110°C	bq294502	SON-6	DRV	4.35	4.0	bq294502DRVR	bq294502DRVT
	bq294504			4.35	6.5	bq294504DRVR	bq294504DRVT
	bq294512			4.40	4.0	bq294512DRVR	bq294512DRVT
	bq294515			4.425	4.0	bq294515DRVR	bq294515DRVT
	bq294522			4.45	4.0	bq294522DRVR	bq294522DRVT
	bq294524			4.45	6.5	bq294524DRVR	bq294524DRVT
	bq294532			4.50	4.0	bq294532DRVR	bq294532DRVT
	bq294562			4.25	4.0	bq294562DRVR	bq294562DRVT
	bq294572			4.00	4.0	bq294572DRVR	bq294572DRVT
	bq294582			4.225	4.0	bq294582DRVR	bq294582DRVT
	bq294584 <sup>(2)</sup>			4.225	6.5	bq294584DRVR	bq294584DRVT
	bq294592			4.30	4.0	bq294592DRVR	bq294592DRVT

(1) For the most current package and ordering information, see the Package Option Addendum at the end of this document, or visit the device product folder on ti.com ([www.ti.com](http://www.ti.com)).

(2) Product Preview only

### THERMAL INFORMATION

THERMAL METRIC <sup>(1)</sup>		bq2945xy	UNITS
		SON	
		6 PINS	
JA	Junction-to-ambient thermal resistance	186.4	°C/W
JC(top)	Junction-to-case(top) thermal resistance	90.4	
JB	Junction-to-board thermal resistance	110.7	
JT	Junction-to-top characterization parameter	96.7	
JB	Junction-to-board characterization parameter	90	
JC(bottom)	Junction-to-case(bottom) thermal resistance	n/a	

(1) For more information about traditional and new thermal metrics, see the *IC Package Thermal Metrics* application report, [SPRA953](http://SPRA953).

## PIN FUNCTIONS

bq2945xy	Pin Name	Type I/O	Description
1	V3	IA	Sense input for positive voltage of the third cell from the bottom of the stack
2	V2	IA	Sense input for positive voltage of the second cell from the bottom of the stack
3	VSS	P	Electrically connected to IC ground and negative terminal of the lowest cell in the stack
4	V1	IA	Sense input for positive voltage of the lowest cell in the stack
5	VDD	P	Power supply
6	OUT	OA	Output drive for external N-Channel FET
Thermal Pad	PWRPAD	—	VSS pin to be connected to the PWRPAD on the printed circuit board for proper operation

## PIN DETAILS

### Description

The voltage sensing for each cell is done independently using a multiplexer. The method of overvoltage detection is comparing the voltage to an overvoltage protection voltage  $V_{OV}$ . Once the voltage exceeds the programmed fixed value, the delay timer circuit is activated. This delay ( $t_{DELAY}$ ) is fixed for either a 4-s or 6.5-s delay. When these conditions are satisfied, the OUT terminal is transitioned to a high level. This output (OUT) is released to a low condition if *all* of the cell inputs ( $V_x$ ) are below the OVP threshold minus the  $V_{phys}$ .

**Figure 1. Timing for Overvoltage Sensing**

### Sense Positive Input for $V_x$

This is an input to sense each single battery cell voltage. A series resistor and a capacitor across the cell for each input is required for noise filtering and stable voltage monitoring.

### Output Drive, OUT

The gate of an external N-Channel MOSFET is connected to this terminal. This output transitions to a high level when an overvoltage condition is detected and after the programmed delay timer. The out will reset to a low level if the cell voltage falls below the  $V_{OV}$  threshold before the fixed delay timer expires.

### Supply Input, VDD

This

### Thermal Pad, PWRPAD

For correct operation, the power pad (PWRPAD) is connected to the  $V_{SS}$  terminal on the printed circuit board.

### FUNCTIONAL BLOCK DIAGRAM

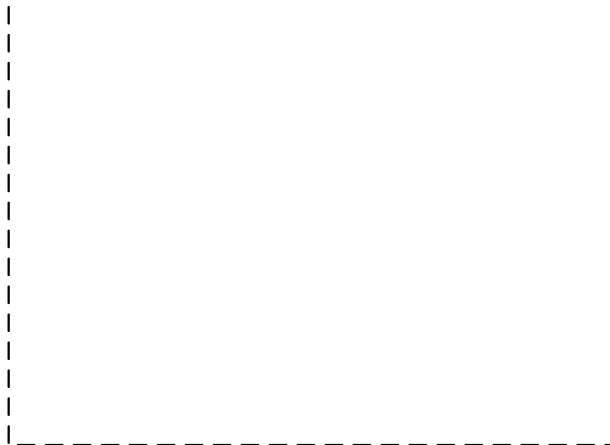

### ABSOLUTE MAXIMUM RATINGS

Over operating free-air temperature range (unless otherwise noted)<sup>(1)</sup>

PARAMETER	CONDITION	VALUE/UNIT
Supply voltage range	VDD–VSS	–0.3 to 30 V
Input voltage range	V1–VSS or V2–VSS or V3–VSS	–0.3 to 30 V
	V3–V2 or V2–V1	–0.3 to 8 V
Output voltage range	OUT–VSS	–0.3 to 30 V
Continuous total power dissipation, $P_{TOT}$		See package dissipation rating.
Functional temperature		–65 to 110°C
Storage temperature range, $T_{STG}$		–65 to 150°C
Lead temperature (soldering, 10 s), $T_{SOLDER}$		300°C

(1) Stresses beyond those listed under “absolute maximum ratings” may cause permanent damage to the device. These are stress ratings only and functional operation of the device at these or any other conditions beyond those indicated under “recommended operating conditions” is not implied. Exposure to absolute-maximum-rated conditions for extended periods may affect device reliability.

### RECOMMENDED OPERATING CONDITIONS

Over operating free-air temperature range (unless otherwise noted)

PARAMETER	MIN	NOM	MAX	UNIT
Supply voltage, $V_{DD}$ <sup>(1)</sup>	3		25	V
Input voltage range   V3–V2 or V2–V1 or V1–VSS	0		5	V
Operating ambient temperature range, $T_A$	–40		110	°C

(1) See [APPLICATION SCHEMATIC](#).



bq294502, bq294504, bq294512, bq294515  
bq294522, bq294524, bq294532, bq294562  
bq294572, bq294582, bq294592

TEXAS  
INSTRUMENTS

SLUSAJ3C - SEPTEMBER 2011 - REVISED MAY 2013 (bq294513C)Tj 36.9 0 Td (-)Tj 4.096.9 .DR

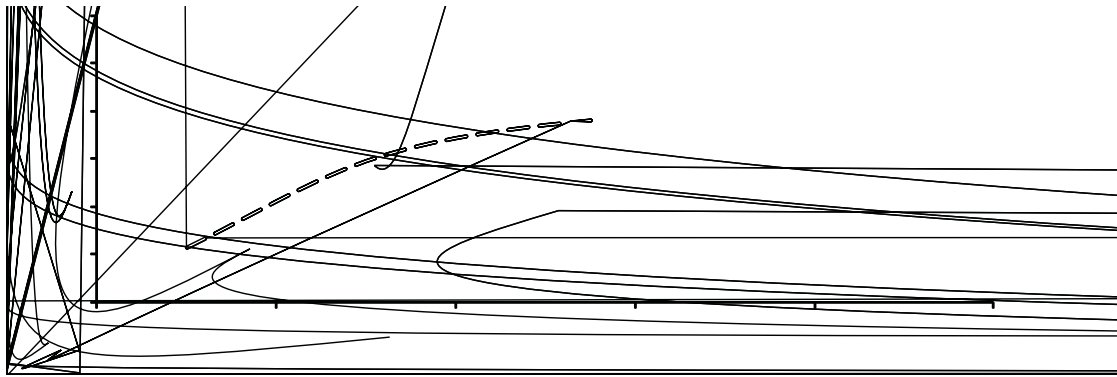
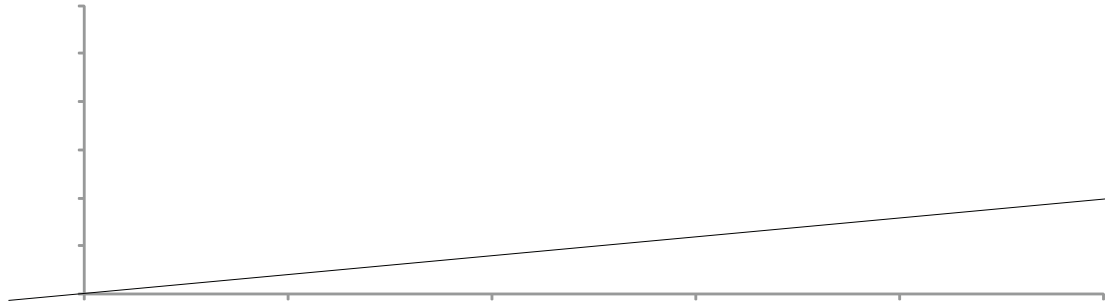
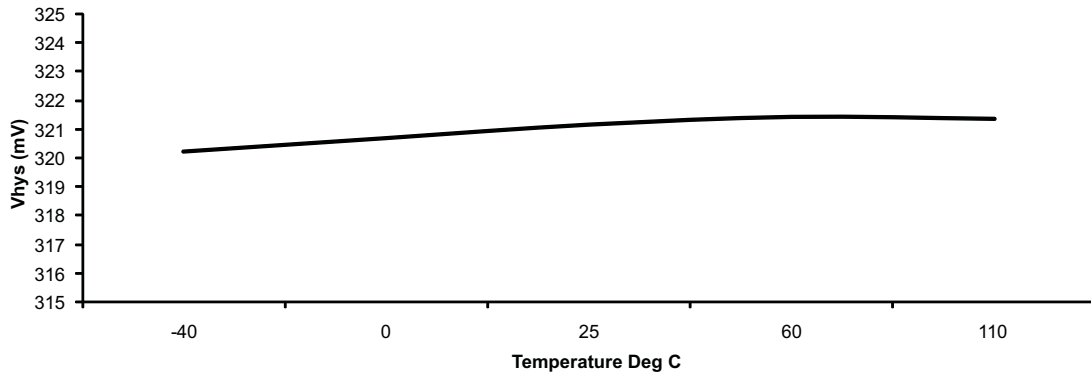

Figure 4. Hysteresis  $V_{HYS}$  Versus Temperature



Figure 5. Output Current  $I_{OUT}$  Versus Temperature

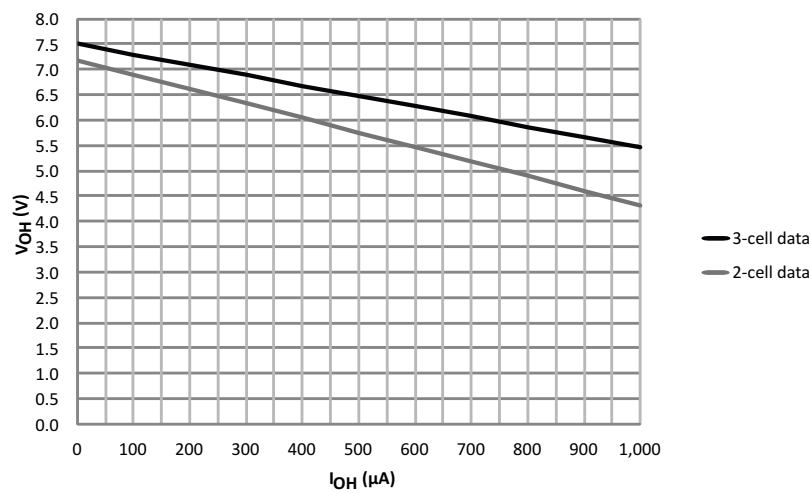

Figure 6. Output Voltage Versus Output Current

## APPLICATION INFORMATION

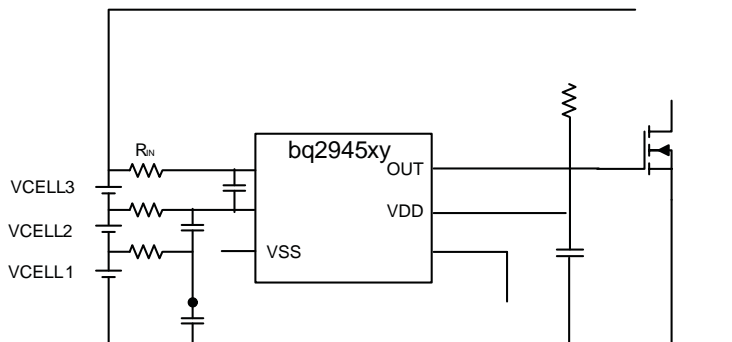

Figure 7. Application Configuration

Changes to the ranges stated in Table 1 will impact the accuracy of the cell measurements. Figure 7 shows each external component.

Table 1. Parameters

PARAMETER	External Component	MIN	NOM	MAX	UNIT
Voltage monitor filter resistance	RIN	900	1000	1100	
Voltage monitor filter capacitance	CIN	0.01		0.1	μF
Supply voltage filter resistance	RVD	100		1K	
Supply voltage filter capacitance	CVD		0.1		μF

## APPLICATION SCHEMATIC

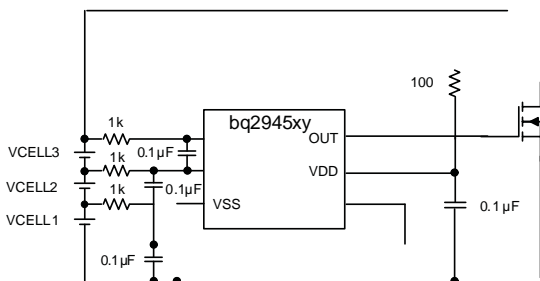

Figure 8. 3-Series Cell Configuration with Fixed Delay

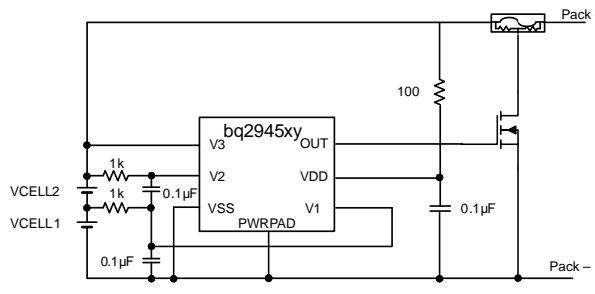

Figure 9. 2-Series Cell Configuration with Internal Fixed Delay

## CUSTOMER TEST MODE

Customer Test Mode (CTM) helps to reduce test time for checking the overvoltage delay timer parameter once the circuit is implemented in the battery pack. To enter CTM, VDD should be set to at least 10 V higher than V3 (see Figure 10). The delay timer is greater than 10 ms, but considerably shorter than the timer delay in normal operation. To exit Customer Test Mode, remove the VDD to VC3 voltage differential of 10 V so that the decrease in this value automatically causes an exit.

### CAUTION

Avoid exceeding any Absolute Maximum Voltages on any pins when placing the part into Customer Test Mode. Also avoid exceeding Absolute Maximum Voltages for the individual cell voltages (V3–V2), (V2–V1), and (V1–VSS). Stressing the pins beyond the rated limits may cause permanent damage to the device.



Figure 10 shows the timing for the Customer Test Mode.

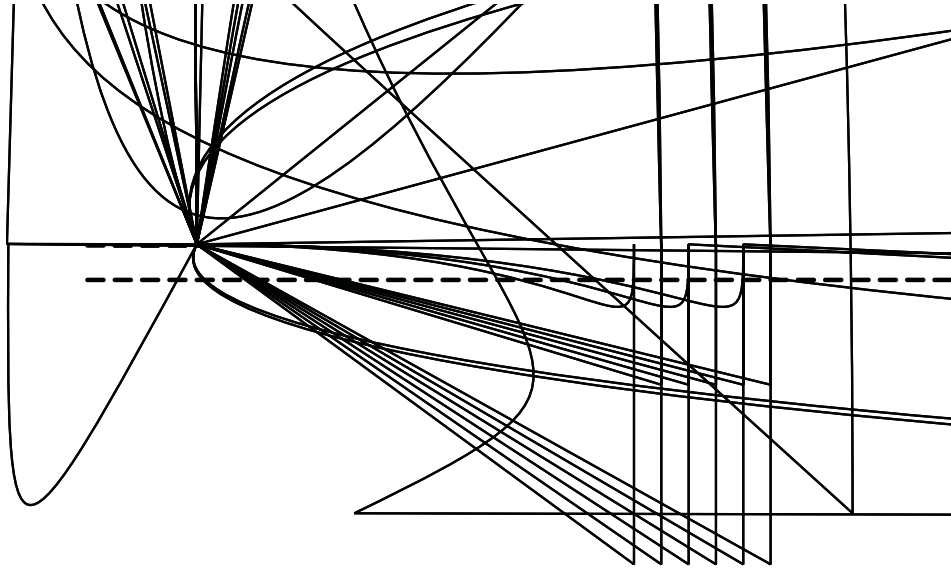

Figure 10. Timing for Customer Test Mode

Figure 11 shows the measurement for current consumption for the product for both VDD and Vx.

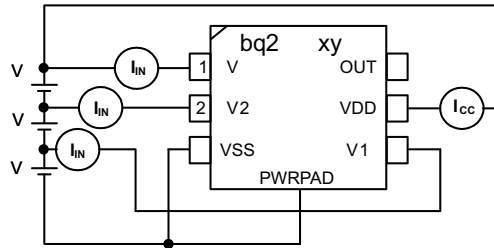

Figure 11. Configuration for IC Current Consumption Test

## REVISION HISTORY

---

### Changes from Original (September 2011) to Revision A Page

- Added the bq294582 Device to Production Data ..... 2
- 

### Changes from Revision A (November 2011) to Revision B Page

- Changed the bq294504 Device to Production Data ..... 1
  - Added the bq294512 Device ..... 1
  - Added the bq294592 Device ..... 1
  - Added a second I<sub>CC</sub> Test Condition ..... 5
  - Changed Fault Detection Delay Time in bq2945x4 Test Mode Specifications ..... 5
- 

### Changes from Revision B (February 2012) to Revision C Page

- Added the bq294515 Device to Production Data ..... 2
  - Added the bq294524 Device to Production Data ..... 2
  - Added the bq294532 Device to Production Data ..... 2
  - Added the bq294572 Device to Production Data ..... 2
  - Changed Overvoltage Detection Hysteresis ..... 5
  - Added Output Voltage Versus Output Current graphic ..... 7
  - Changed Timing for Customer Test Mode figure ..... 9
-

**PACKAGING INFORMATION**

Orderable Device	Status (1)	Package Type	Package Drawing	Pins	Package Qty	Eco Plan (2)	Lead/Ball Finish	MSL Peak Temp (3)	Op Temp (°C)	Top-Side Markings (4)	Samples
BQ294502DRVR	ACTIVE	SON	DRV	6	3000	Green (RoHS & no Sb/Br)	CU NIPDAU	Level-2-260C-1 YEAR	-40 to 85	4502	<a href="#">Samples</a>
BQ294502DRVT	ACTIVE	SON	DRV	6	250	Green (RoHS & no Sb/Br)	CU NIPDAU	Level-2-260C-1 YEAR	-40 to 85	4502	<a href="#">Samples</a>
BQ294504DRVR	PREVIEW	SON	DRV	6		Green (RoHS & no Sb/Br)	CU NIPDAU	Level-2-260C-1 YEAR	-40 to 85	4504	
BQ294504DRVT	PREVIEW	SON	DRV	6		Green (RoHS & no Sb/Br)	CU NIPDAU	Level-2-260C-1 YEAR	-40 to 85	4504	
BQ294512DRVR	ACTIVE	SON	DRV	6	3000	Green (RoHS & no Sb/Br)	CU NIPDAU	Level-2-260C-1 YEAR	-40 to 85	4512	<a href="#">Samples</a>
BQ294512DRVT	ACTIVE	SON	DRV	6	250	Green (RoHS & no Sb/Br)	CU NIPDAU	Level-2-260C-1 YEAR	-40 to 85	4512	<a href="#">Samples</a>
BQ294515DRVR	PREVIEW	SON	DRV	6	3000	Green (RoHS & no Sb/Br)	CU NIPDAU	Level-2-260C-1 YEAR	-40 to 85	4515	
BQ294515DRVT	PREVIEW	SON	DRV	6		Green (RoHS & no Sb/Br)	CU NIPDAU	Level-2-260C-1 YEAR	-40 to 85	4515	
BQ294522DRVR	ACTIVE	SON	DRV	6	3000	Green (RoHS & no Sb/Br)	CU NIPDAU	Level-2-260C-1 YEAR	-40 to 85	4522	<a href="#">Samples</a>
BQ294522DRVT	ACTIVE	SON	DRV	6	250	Green (RoHS & no Sb/Br)	CU NIPDAU	Level-2-260C-1 YEAR	-40 to 85	4522	<a href="#">Samples</a>
BQ294524DRVR	ACTIVE	SON	DRV	6	3000	Green (RoHS & no Sb/Br)	CU NIPDAU	Level-2-260C-1 YEAR	-40 to 85	4524	<a href="#">Samples</a>
BQ294524DRVT	ACTIVE	SON	DRV	6	250	Green (RoHS & no Sb/Br)	CU NIPDAU	Level-2-260C-1 YEAR	-40 to 85	4524	<a href="#">Samples</a>
BQ294532DRVR	ACTIVE	SON	DRV	6	3000	Green (RoHS & no Sb/Br)	CU NIPDAU	Level-2-260C-1 YEAR	-40 to 85	4532	<a href="#">Samples</a>
BQ294532DRVT	ACTIVE	SON	DRV	6	250	Green (RoHS & no Sb/Br)	CU NIPDAU	Level-2-260C-1 YEAR	-40 to 85	4532	<a href="#">Samples</a>
BQ294582DRVR	ACTIVE	SON	DRV	6	3000	Green (RoHS & no Sb/Br)	CU NIPDAU	Level-2-260C-1 YEAR	-40 to 85	4582	<a href="#">Samples</a>
BQ294582DRVT	ACTIVE	SON	DRV	6	250	Green (RoHS & no Sb/Br)	CU NIPDAU	Level-2-260C-1 YEAR	-40 to 85	4582	<a href="#">Samples</a>
BQ294592DRVR	ACTIVE	SON	DRV	6	3000	Green (RoHS & no Sb/Br)	CU NIPDAU	Level-2-260C-1 YEAR	-40 to 85	4592	<a href="#">Samples</a>

Orderable Device	Status (1)	Package Type	Package Drawing	Pins	Package Qty	Eco Plan (2)	Lead/Ball Finish	MSL Peak Temp (3)	Op Temp (°C)	Top-Side Markings (4)	Samples
BQ294592DRVT	ACTIVE	SON	DRV	6	250	Green (RoHS & no Sb/Br)	CU NIPDAU	Level-2-260C-1 YEAR	-40 to 85	4592	<a href="#">Samples</a>

(1) The marketing status values are defined as follows:

**ACTIVE:** Product device recommended for new designs.

**LIFEBUY:** TI has announced that the device will be discontinued, and a lifetime-buy period is in effect.

**NRND:** Not recommended for new designs. Device is in production to support existing customers, but TI does not recommend using this part in a new design.

**PREVIEW:** Device has been announced but is not in production. Samples may or may not be available.

**OBSOLETE:** TI has discontinued the production of the device.

(2) Eco Plan - The planned eco-friendly classification: Pb-Free (RoHS), Pb-Free (RoHS Exempt), or Green (RoHS & no Sb/Br) - please check <http://www.ti.com/productcontent> for the latest availability information and additional product content details.

**TBD:** The Pb-Free/Green conversion plan has not been defined.

**Pb-Free (RoHS):** TI's terms "Lead-Free" or "Pb-Free" mean semiconductor products that are compatible with the current RoHS requirements for all 6 substances, including the requirement that lead not exceed 0.1% by weight in homogeneous materials. Where designed to be soldered at high temperatures, TI Pb-Free products are suitable for use in specified lead-free processes.

**Pb-Free (RoHS Exempt):** This component has a RoHS exemption for either 1) lead-based flip-chip solder bumps used between the die and package, or 2) lead-based die adhesive used between the die and leadframe. The component is otherwise considered Pb-Free (RoHS compatible) as defined above.

**Green (RoHS & no Sb/Br):** TI defines "Green" to mean Pb-Free (RoHS compatible), and free of Bromine (Br) and Antimony (Sb) based flame retardants (Br or Sb do not exceed 0.1% by weight in homogeneous material)

(3) MSL, Peak Temp. -- The Moisture Sensitivity Level rating according to the JEDEC industry standard classifications, and peak solder temperature.

(4) Only one of markings shown within the brackets will appear on the physical device.

**Important Information and Disclaimer:** The information provided on this page represents TI's knowledge and belief as of the date that it is provided. TI bases its knowledge and belief on information provided by third parties, and makes no representation or warranty as to the accuracy of such information. Efforts are underway to better integrate information from third parties. TI has taken and continues to take reasonable steps to provide representative and accurate information but may not have conducted destructive testing or chemical analysis on incoming materials and chemicals. TI and TI suppliers consider certain information to be proprietary, and thus CAS numbers and other limited information may not be available for release.

In no event shall TI's liability arising out of such information exceed the total purchase price of the TI part(s) at issue in this document sold by TI to Customer on an annual basis.

## TAPE AND REEL INFORMATION

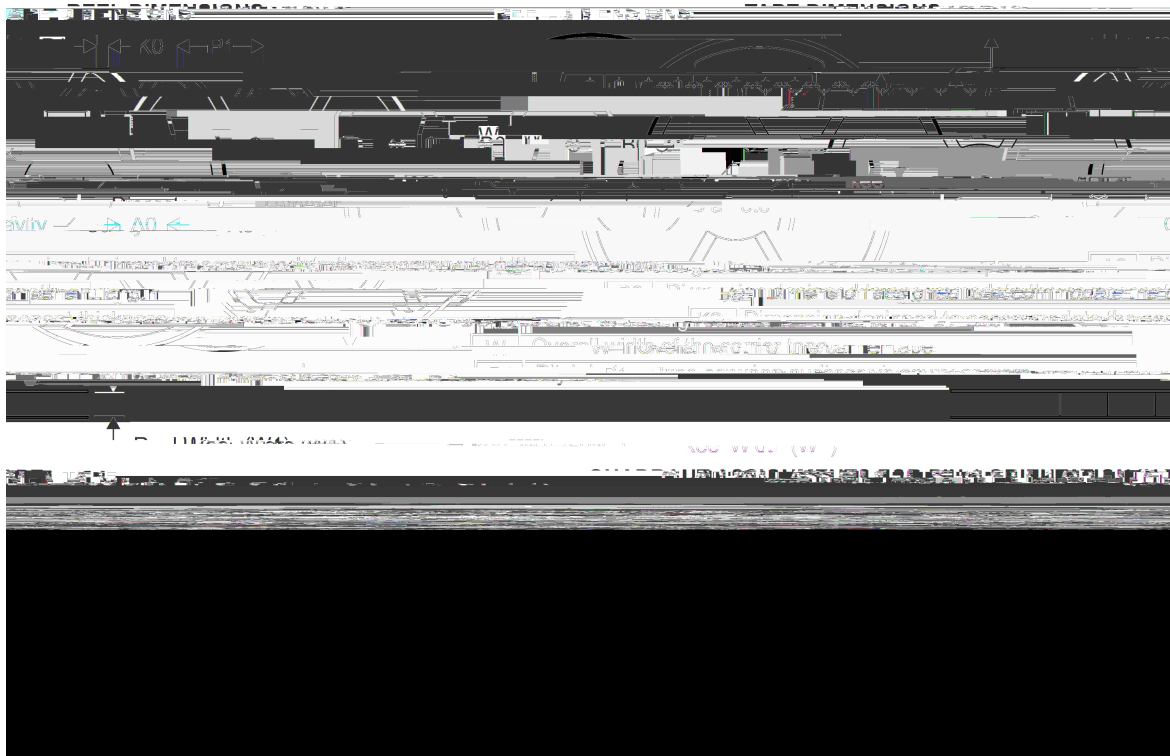

\*All dimensions are nominal

Device	Package Type	Package Drawing	Pins	SPQ	Reel Diameter (mm)	Reel Width W1 (mm)	A0 (mm)	B0 (mm)	K0 (mm)	P1 (mm)	W (mm)	Pin1 Quadrant
BQ294502DRVR	SON	DRV	6	3000	330.0	12.4	2.2	2.2	1.1	8.0	12.0	Q2
BQ294502DRVT	SON	DRV	6	250	180.0	12.4	2.2	2.2	1.1	8.0	12.0	Q2
BQ294504DRVR	SON	DRV	6	0	330.0	12.4	2.2	2.2	1.1	8.0	12.0	Q2
BQ294504DRVT	SON	DRV	6	0	180.0	12.4	2.2	2.2	1.1	8.0	12.0	Q2
BQ294512DRVR	SON	DRV	6	3000	330.0	12.4	2.2	2.2	1.1	8.0	12.0	Q2
BQ294512DRVT	SON	DRV	6	250	180.0	12.4	2.2	2.2	1.1	8.0	12.0	Q2
BQ294522DRVR	SON	DRV	6	3000	330.0	12.4	2.2	2.2	1.1	8.0	12.0	Q2
BQ294522DRVT	SON	DRV	6	250	180.0	12.4	2.2	2.2	1.1	8.0	12.0	Q2
BQ294524DRVR	SON	DRV	6	3000	330.0	12.4	2.2	2.2	1.1	8.0	12.0	Q2
BQ294524DRVT	SON	DRV	6	250	180.0	12.4	2.2	2.2	1.1	8.0	12.0	Q2
BQ294532DRVR	SON	DRV	6	3000	330.0	12.4	2.2	2.2	1.1	8.0	12.0	Q2
BQ294532DRVT	SON	DRV	6	250	180.0	12.4	2.2	2.2	1.1	8.0	12.0	Q2
BQ294582DRVR	SON	DRV	6	3000	330.0	12.4	2.2	2.2	1.1	8.0	12.0	Q2
BQ294582DRVT	SON	DRV	6	250	180.0	12.4	2.2	2.2	1.1	8.0	12.0	Q2
BQ294592DRVR	SON	DRV	6	3000	330.0	12.4	2.2	2.2	1.1	8.0	12.0	Q2
BQ294592DRVT	SON	DRV	6	250	180.0	12.4	2.2	2.2	1.1	8.0	12.0	Q2

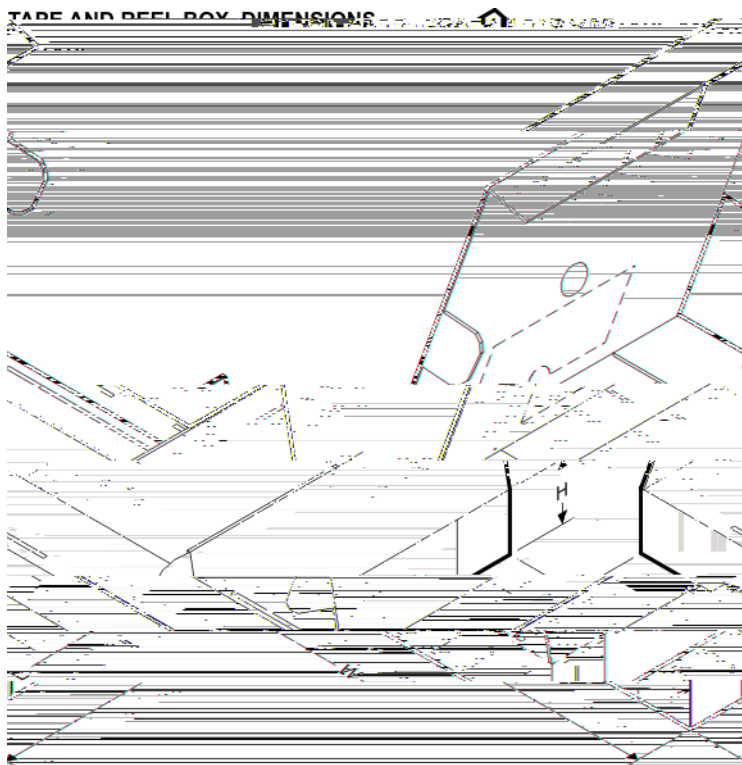

\*All dimensions are nominal

Device	Package Type	Package Drawing	Pins	SPQ	Length (mm)	Width (mm)	Height (mm)
BQ294502DRVR	SON	DRV	6	3000	367.0	367.0	35.0
BQ294502DRVT	SON	DRV	6	250	210.0	185.0	35.0
BQ294504DRVR	SON	DRV	6	0	367.0	367.0	35.0
BQ294504DRVT	SON	DRV	6	0	210.0	185.0	35.0
BQ294512DRVR	SON	DRV	6	3000	367.0	367.0	35.0
BQ294512DRVT	SON	DRV	6	250	210.0	185.0	35.0
BQ294522DRVR	SON	DRV	6	3000	367.0	367.0	35.0
BQ294522DRVT	SON	DRV	6	250	210.0	185.0	35.0
BQ294524DRVR	SON	DRV	6	3000	367.0	367.0	35.0
BQ294524DRVT	SON	DRV	6	250	210.0	185.0	35.0
BQ294532DRVR	SON	DRV	6	3000	367.0	367.0	35.0
BQ294532DRVT	SON	DRV	6	250	210.0	185.0	35.0
BQ294582DRVR	SON	DRV	6	3000	367.0	367.0	35.0
BQ294582DRVT	SON	DRV	6	250	210.0	185.0	35.0
BQ294592DRVR	SON	DRV	6	3000	367.0	367.0	35.0
BQ294592DRVT	SON	DRV	6	250	210.0	185.0	35.0

MECHANICAL D/

REF.

EXTING

erancing pe

and end of  
of the exposed thermal part

N  
i.com

# PLASTI

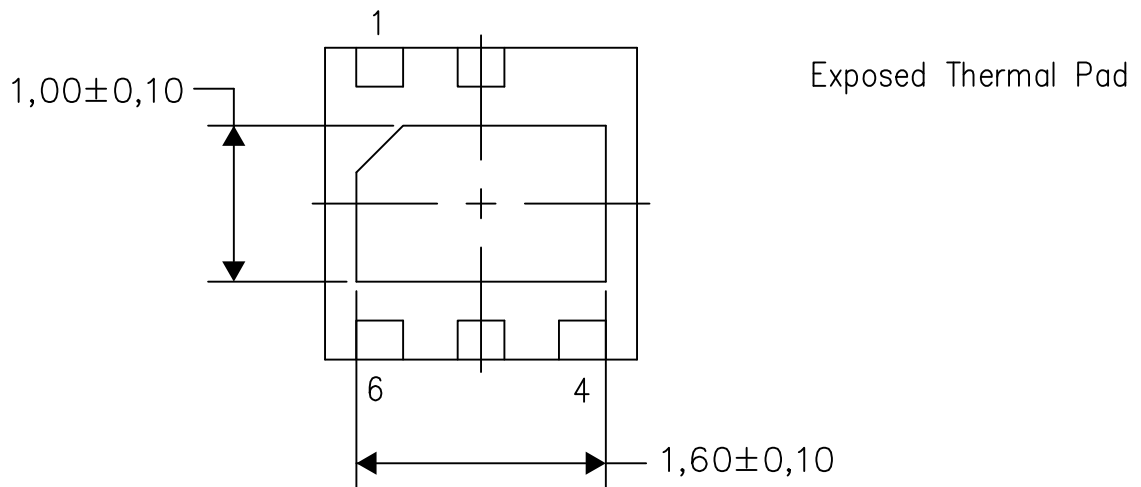

Exposed Thermal Pad

Bottom View

Exposed Thermal Pad Dimensions

NOTE: All linear dimensions are in millimeters



Note D

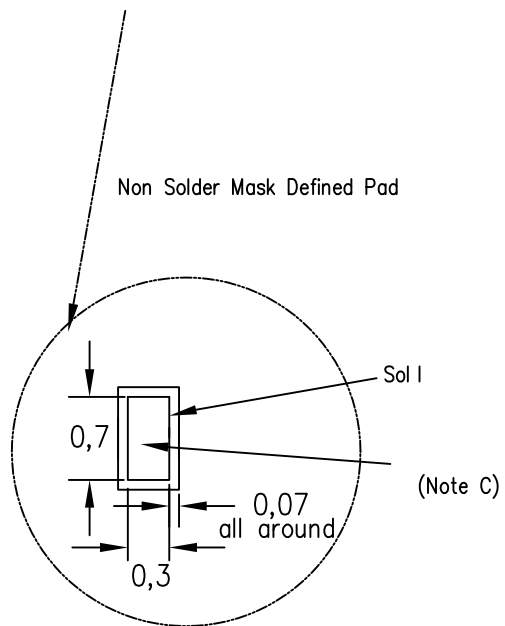

- NOTES: A. All linear dimensions are in millimeters.  
B. This drawing is subject to change without notice.  
C. Publication IPC-7351 is recommended for alternate designs.

QFN/SON PCB Attachment, Texas Instruments Literature No. ~~SLUA~~  
for specific thermal information, via requirements, and recommended board layout.  
These documents are available at [www.ti.com](http://www.ti.com) <<http://www.ti.com>>.

E.

F. [www.ti.com](#) fabrication site for solder mask tolerances.

## IMPORTANT NOTICE

Texas Instruments Incorporated and its subsidiaries (TI) reserve the right to make corrections, enhancements, improvements and other changes to its semiconductor products and services per JESD46, latest issue, and to discontinue any product or service per JESD48, latest issue. Buyers should obtain the latest relevant information before placing orders and should verify that such information is current and complete. All semiconductor products (also referred to herein as "components") are sold subject to TI's terms and conditions of sale supplied at the time of order acknowledgment.

TI warrants performance of its components to the specifications applicable at the time of sale, in accordance with the warranty in TI's terms and conditions of sale of semiconductor products. Testing and other quality control techniques are used to the extent TI deems necessary to support this warranty. Except where mandated by applicable law, testing of all parameters of each component is not necessarily performed.

TI assumes no liability for applications assistance or the design of Buyers' products. Buyers are responsible for their products and applications using TI components. To minimize the risks associated with Buyers' products and applications, Buyers should provide adequate design and operating safeguards.

TI does not warrant or represent that any license, either express or implied, is granted under any patent right, copyright, mask work right, or other intellectual property right relating to any combination, machine, or process in which TI components or services are used. Information published by TI regarding third-party products or services does not constitute a license to use such products or services or a warranty or endorsement thereof. Use of such information may require a license from a third party under the patents or other intellectual property of the third party, or a license from TI under the patents or other intellectual property of TI.

Reproduction of significant portions of TI information in TI data books or data sheets is permissible only if reproduction is without alteration and is accompanied by all associated warranties, conditions, limitations, and notices. TI is not responsible or liable for such altered documentation. Information of third parties may be subject to additional restrictions.

Resale of TI components or services with statements different from or beyond the parameters stated by TI for that component or service voids all express and any implied warranties for the associated TI component or service and is an unfair and deceptive business practice. TI is not responsible or liable for any such statements.

Buyer acknowledges and agrees that it is solely responsible for compliance with all legal, regulatory and safety-related requirements concerning its products, and any use of TI components in its applications, notwithstanding any applications-related information or support that may be provided by TI. Buyer represents and agrees that it has all the necessary expertise to create and implement safeguards which anticipate dangerous consequences of failures, monitor failures and their consequences, lessen the likelihood of failures that might cause harm and take appropriate remedial actions. Buyer will fully indemnify TI and its representatives against any damages arising out of the use of any TI components in safety-critical applications.

In some cases, TI components may be promoted specifically to facilitate safety-related applications. With such components, TI's goal is to help enable customers to design and create their own end-product solutions that meet applicable functional safety standards and requirements. Nonetheless, such components are subject to these terms.

No TI components are authorized for use in FDA Class III (or similar life-critical medical equipment) unless authorized officers of the parties have executed a special agreement specifically governing such use.

Only those TI components which TI has specifically designated as military grade or "enhanced plastic" are designed and intended for use in military/aerospace applications or environments. Buyer acknowledges and agrees that any military or aerospace use of TI components which have **not** been so designated is solely at the Buyer's risk, and that Buyer is solely responsible for compliance with all legal and regulatory requirements in connection with such use.

TI has specifically designated certain components as meeting ISO/TS16949 requirements, mainly for automotive use. In any case of use of non-designated products, TI will not be responsible for any failure to meet ISO/TS16949.

### Products

Audio	<a href="http://www.ti.com/audio">www.ti.com/audio</a>
Amplifiers	<a href="http://amplifier.ti.com">amplifier.ti.com</a>
Data Converters	<a href="http://dataconverter.ti.com">dataconverter.ti.com</a>
DLP® Products	<a href="http://www.dlp.com">www.dlp.com</a>
DSP	<a href="http://dsp.ti.com">dsp.ti.com</a>
Clocks and Timers	<a href="http://www.ti.com/clocks">www.ti.com/clocks</a>
Interface	<a href="http://interface.ti.com">interface.ti.com</a>
Logic	<a href="http://logic.ti.com">logic.ti.com</a>
Power Mgmt	<a href="http://power.ti.com">power.ti.com</a>
Microcontrollers	<a href="http://microcontroller.ti.com">microcontroller.ti.com</a>
RFID	<a href="http://www.ti-rfid.com">www.ti-rfid.com</a>
OMAP Applications Processors	<a href="http://www.ti.com/omap">www.ti.com/omap</a>
Wireless Connectivity	<a href="http://www.ti.com/wirelessconnectivity">www.ti.com/wirelessconnectivity</a>

### Applications

Automotive and Transportation	<a href="http://www.ti.com/automotive">www.ti.com/automotive</a>
Communications and Telecom	<a href="http://www.ti.com/communications">www.ti.com/communications</a>
Computers and Peripherals	<a href="http://www.ti.com/computers">www.ti.com/computers</a>
Consumer Electronics	<a href="http://www.ti.com/consumer-apps">www.ti.com/consumer-apps</a>
Energy and Lighting	<a href="http://www.ti.com/energy">www.ti.com/energy</a>
Industrial	<a href="http://www.ti.com/industrial">www.ti.com/industrial</a>
Medical	<a href="http://www.ti.com/medical">www.ti.com/medical</a>
Security	<a href="http://www.ti.com/security">www.ti.com/security</a>
Space, Avionics and Defense	<a href="http://www.ti.com/space-avionics-defense">www.ti.com/space-avionics-defense</a>
Video and Imaging	<a href="http://www.ti.com/video">www.ti.com/video</a>

### TI E2E Community

[e2e.ti.com](http://e2e.ti.com)