

Customer Information Sheet

DRAWING No.: S7091-42R

SHEET 2 OF 2

IF IN DOUBT - ASK

©

NOT TO SCALE

THIRD ANGLE PROJECTION

ALL DIMENSIONS IN mm

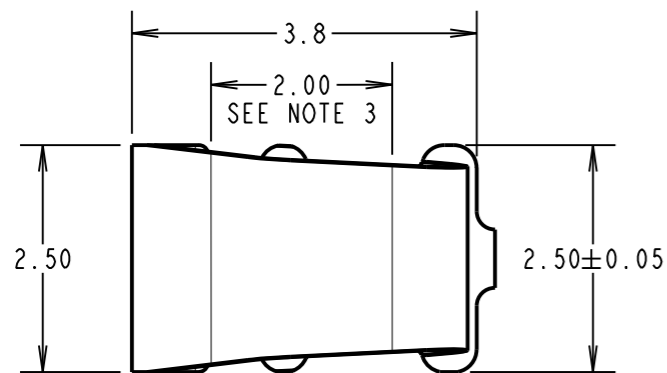
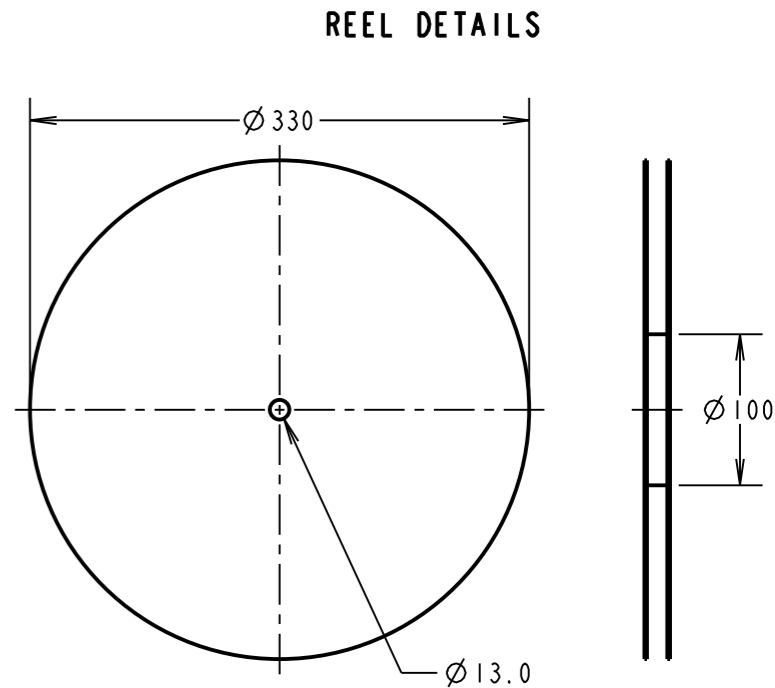
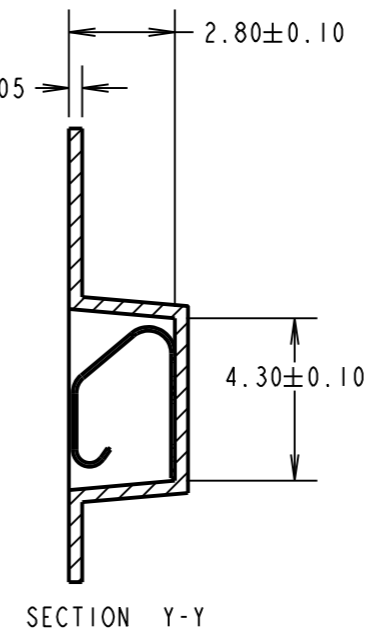
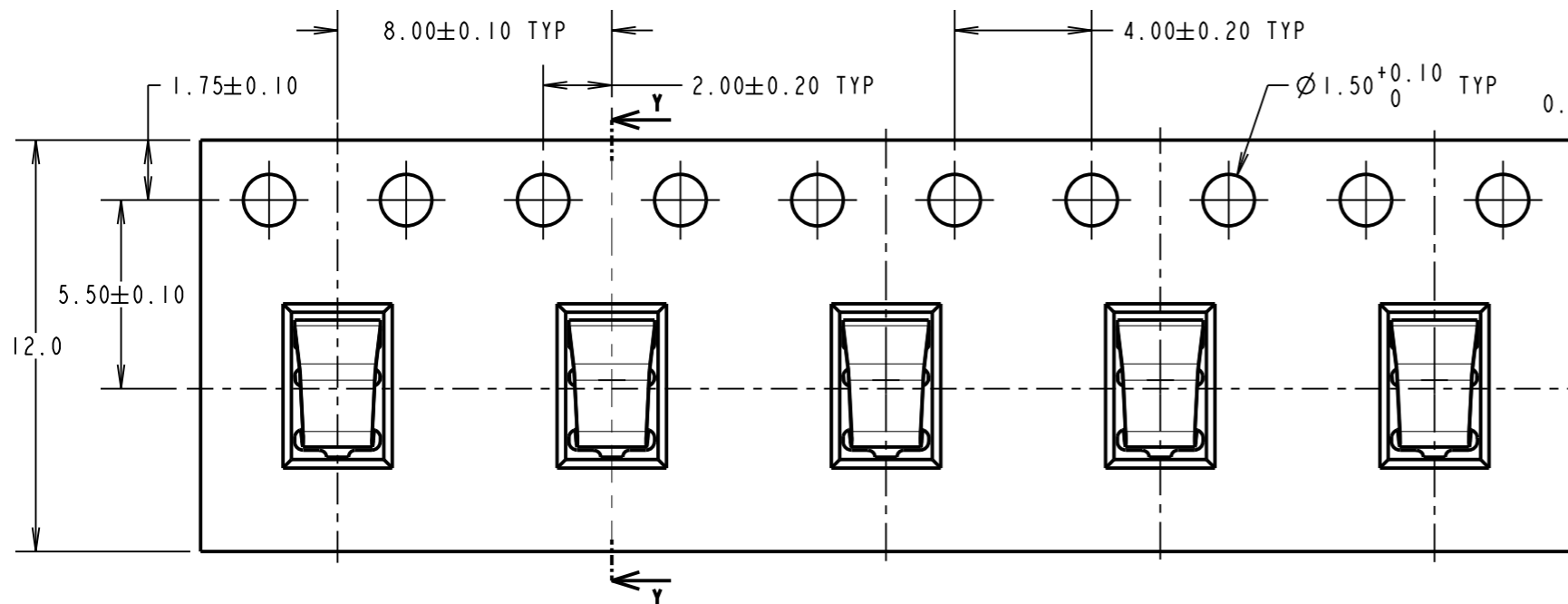

RECOMMENDED PAD LAYOUT

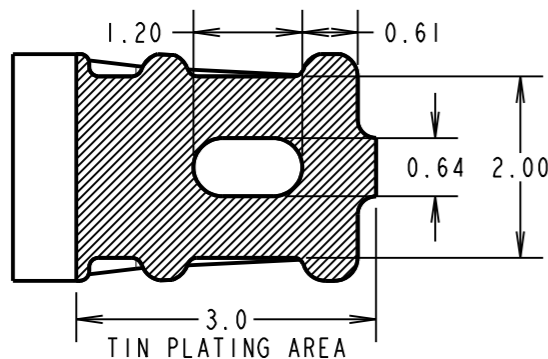
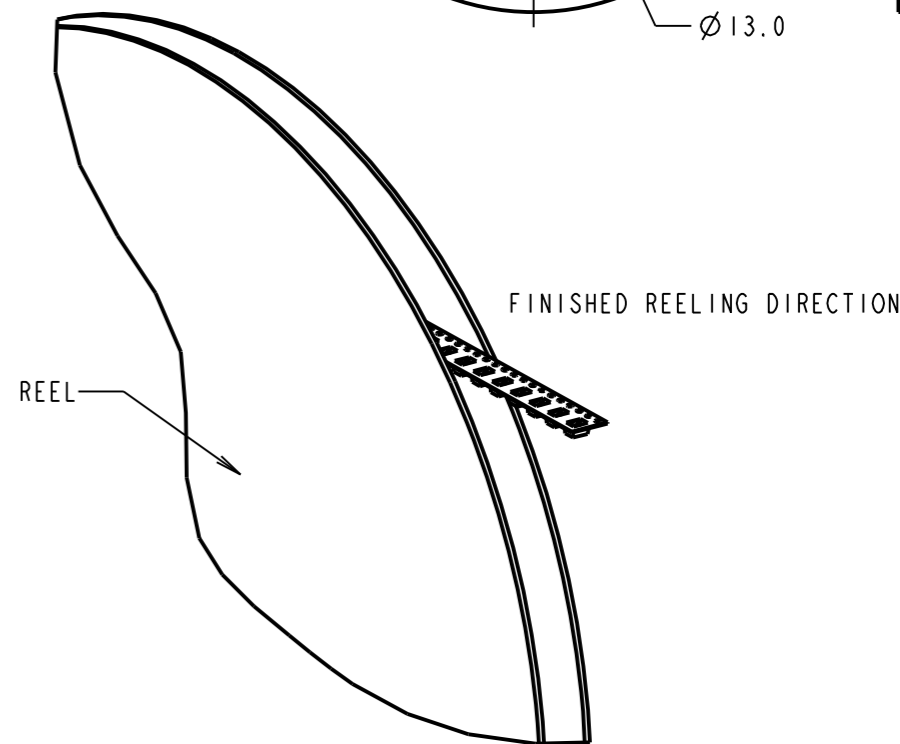
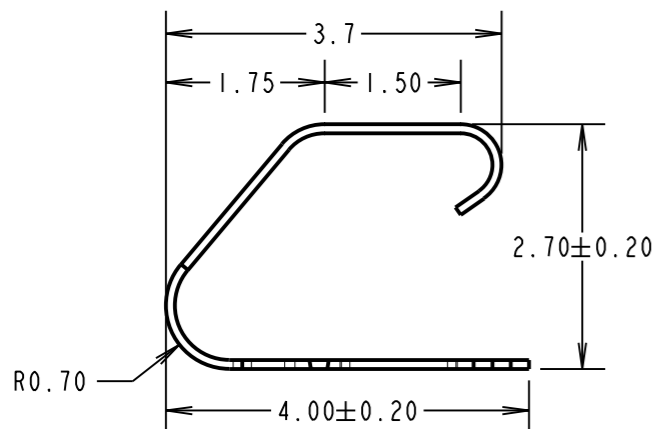
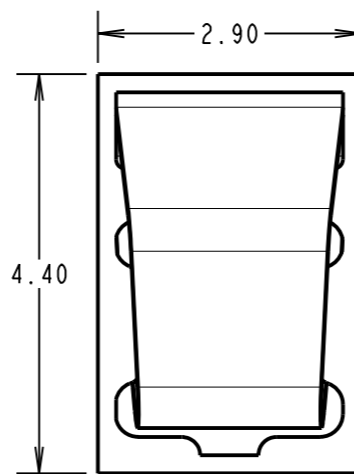

COMPONENT SPECIFICATION
 MATERIAL = TITANIUM COPPER ALLOY
 0.10mm THICK
 FINISH = 0.7µ-1.3µ NICKEL, GOLD FLASH
 ON CONTACT AND 2.54µ MIN 100%
 TIN ON FOOT AREA.
 RECOMMENDED WORKING HEIGHT = 2.30mm / MIN FORCE = 1.2N
 RECOMMENDED MINIMUM WORKING HEIGHT = 1.90mm

NOTES:
 1. QUANTITY PER REEL = 2500
 2. AREA FOR GOLD PLATE
 3. ALL TOLERANCES ARE: X.X = ±0.30mm
 X.XX = ±0.10mm
 X.XXX = ±0.01mm
 UNLESS OTHERWISE STATED.

SB	4	07.03.12	11655
NAME	ISS.	DATE	C/NOTE
APPROVED:		S.BENNETT	
CHECKED:		S.FLOWER	
DRAWN:		R.ADDE	
CUSTOMER REF.:			
ASSEMBLY DRG:			

HARWIN

www.harwin.com
 technical@harwin.com

THIS DRAWING AND ANY INFORMATION OR DESCRIPTIVE MATTER SET OUT HEREON ARE CONFIDENTIAL AND COPYRIGHT PROPERTY OF THE HARWIN GROUP AND MUST NOT BE DISCLOSED, LOANED, COPIED OR USED FOR MANUFACTURING, TENDERING OR FOR ANY OTHER PURPOSE WITHOUT THEIR WRITTEN PERMISSION.

TOLERANCES
 X = ±1mm
 X.X = ±0.25mm
 X.XX = ±0.10mm
 X.XXX = ±0.01mm
 ANGLES = ±5°
 UNLESS STATED

MATERIAL: SEE ABOVE
 FINISH: SEE ABOVE
 S/AREA: mm²

TITLE: SMT SHIELD FINGER (2.7mm) IN TAPE AND REEL

DRAWING NUMBER: S7091-42R

SHT 2 OF 2