

Customer Information Sheet

DRAWING No.: SI411-XXR

SHEET 2 OF 2

IF IN DOUBT - ASK

©

NOT TO SCALE

THIRD ANGLE PROJECTION

ALL DIMENSIONS IN mm

INCHES CONVERSIONS IN ()

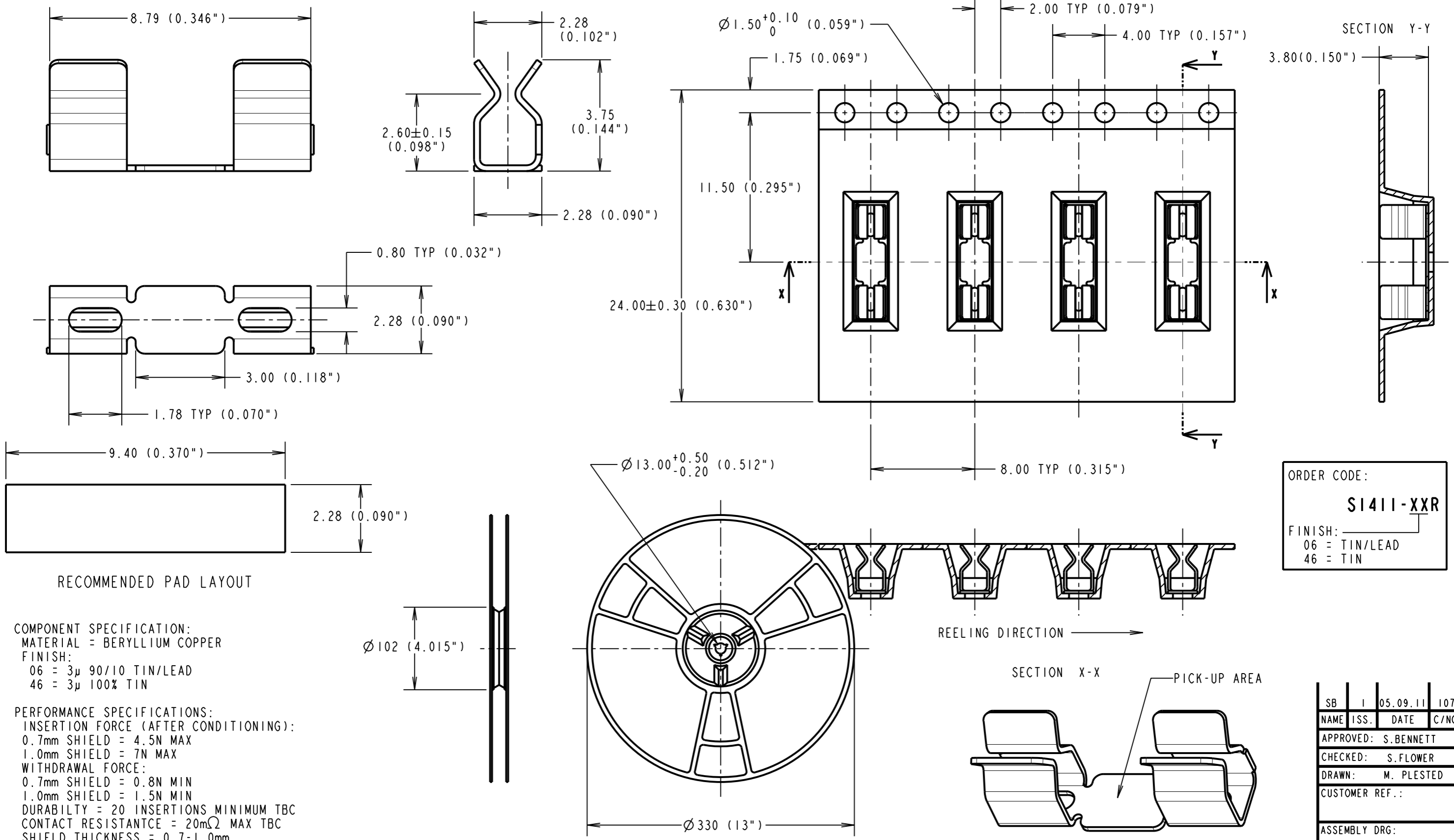

ORDER CODE:
SI411-XXR
FINISH:
06 = TIN/LEAD
46 = TIN

COMPONENT SPECIFICATION:
MATERIAL = BERYLLIUM COPPER
FINISH:
06 = 3µ 90/10 TIN/LEAD
46 = 3µ 100% TIN

PERFORMANCE SPECIFICATIONS:
INSERTION FORCE (AFTER CONDITIONING):
0.7mm SHIELD = 4.5N MAX
1.0mm SHIELD = 7N MAX
WITHDRAWAL FORCE:
0.7mm SHIELD = 0.8N MIN
1.0mm SHIELD = 1.5N MIN
DURABILITY = 20 INSERTIONS MINIMUM TBC
CONTACT RESISTANCE = 20mΩ MAX TBC
SHIELD THICKNESS = 0.7-1.0mm

NOTES:
1. QUANTITY PER REEL = 1,900.
2. THIS PRODUCT IS TAPED AND REELED IN ACCORDANCE WITH EIA-481 (ELECTRONIC INDUSTRIES ASSOCIATION).
3. ALL SPECIFICATIONS SUBJECT TO VERIFICATION.

HARWIN			THIS DRAWING AND ANY INFORMATION OR DESCRIPTIVE MATTER SET OUT HEREON ARE CONFIDENTIAL AND COPYRIGHT PROPERTY OF THE HARWIN GROUP AND MUST NOT BE DISCLOSED, LOANED, COPIED OR USED FOR MANUFACTURING, TENDERING OR FOR ANY OTHER PURPOSE WITHOUT THEIR WRITTEN PERMISSION.	TOLERANCES	MATERIAL:	TITLE:
HARWIN USA TEL: 603 893 5376 FAX: 603 893 5396 mis@harwin.com	HARWIN Europe (UK) TEL: 023 9231 4545 FAX: 023 9231 4590 mis@harwin.co.uk	HARWIN Asia TEL: +65 6 779 4909 FAX: +65 6 779 3868 mis@harwin.com.sg		X. = ±1mm X.X = ±0.25mm X.XX = ±0.10mm X.XXX = ±0.01mm ANGLES = ±5° UNLESS STATED	SEE ABOVE	SMT RFI SHIELD CLIP IN TAPE AND REEL
				FINISH: SEE ABOVE	DRAWING NUMBER:	SHT 2 OF 2
				S/AREA: mm ²	SI411-XXR	

SB	1	05.09.11	10700
NAME	ISS.	DATE	C/NOTE
APPROVED: S.BENNETT			
CHECKED: S.FLOWER			
DRAWN: M. PLESTED			
CUSTOMER REF.:			
ASSEMBLY DRG:			