

# Customer Information Sheet

DRAWING No.: S7081-42R

SHEET 2 OF 2

IF IN DOUBT - ASK

©

NOT TO SCALE

THIRD ANGLE PROJECTION

ALL DIMENSIONS IN mm

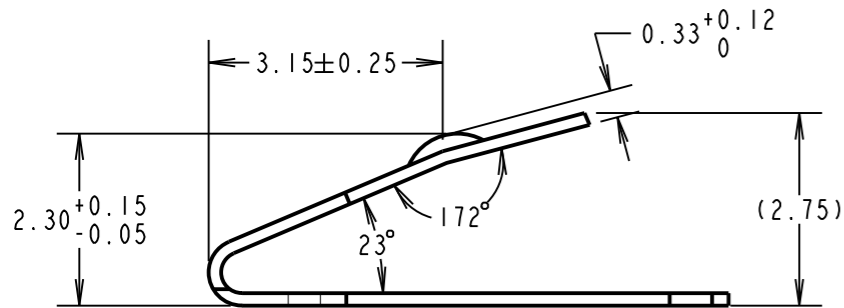
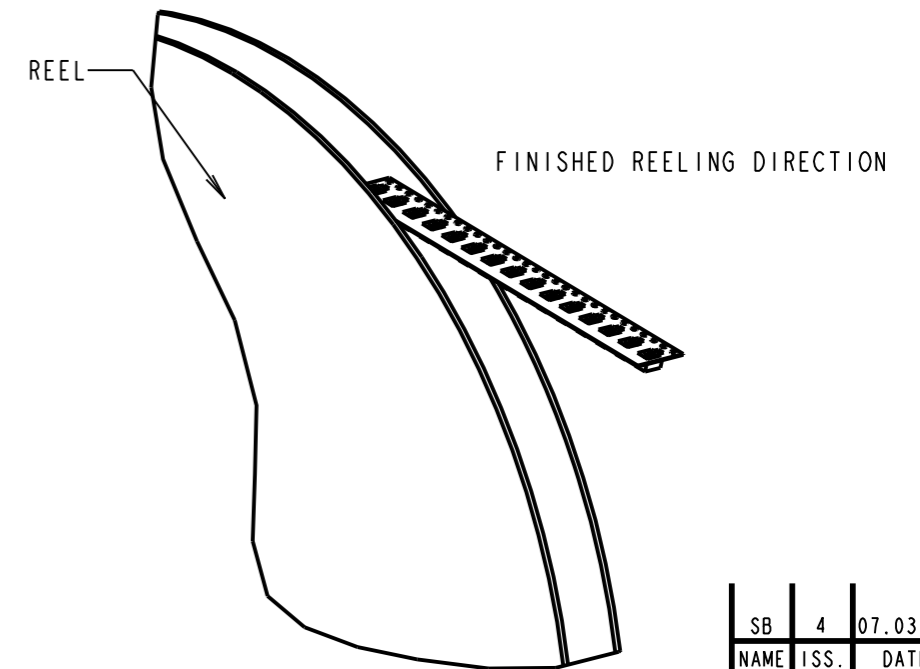
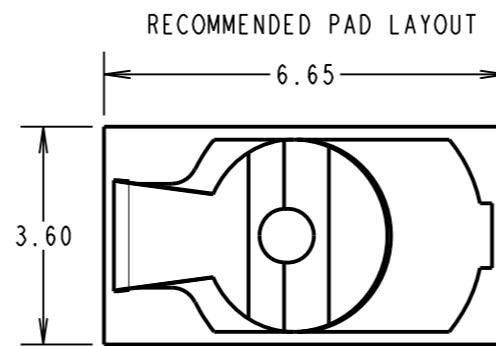
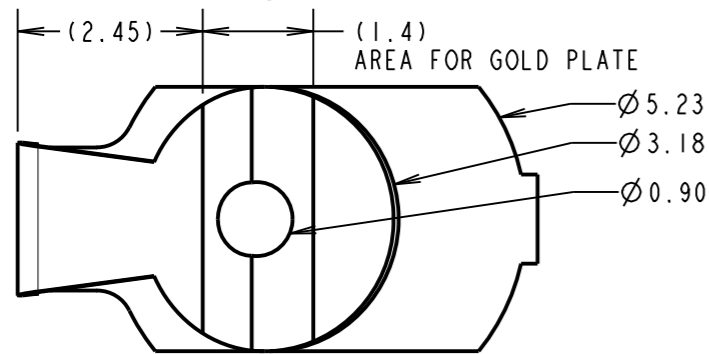
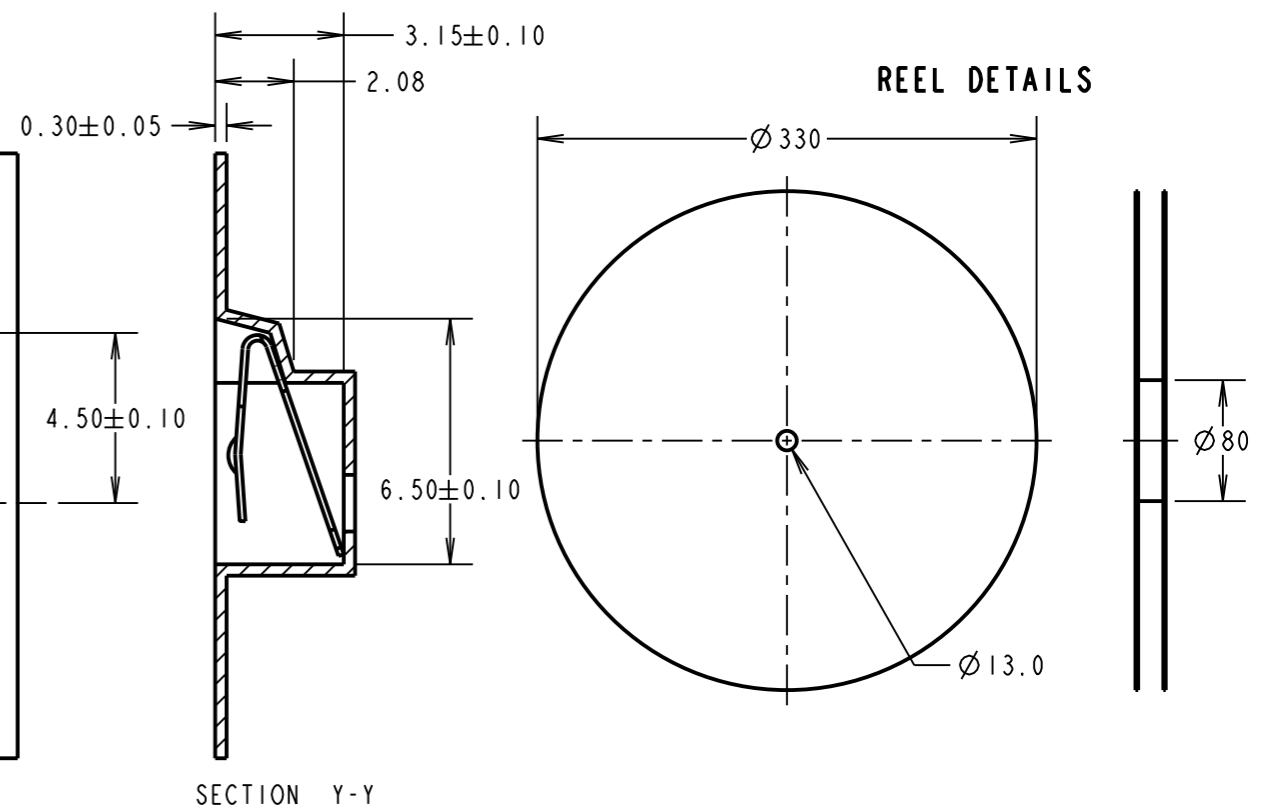
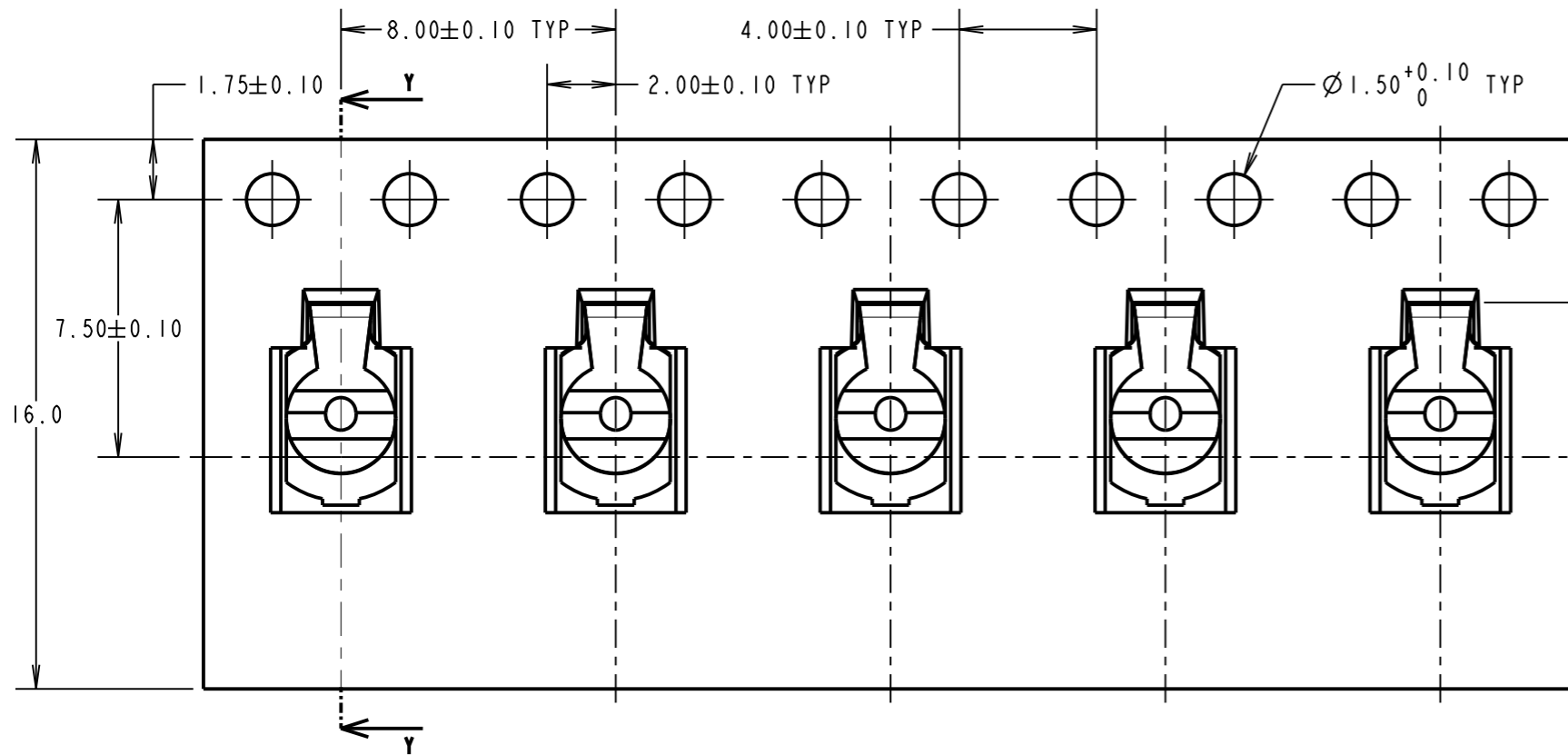

**COMPONENT SPECIFICATION**

MATERIAL = TITANIUM COPPER ALLOY,  
0.15mm THICK

FINISH = 0.7 $\mu$ -1.3 $\mu$  NICKEL, GOLD FLASH  
ON CONTACTS AND 2.54 $\mu$  MIN 100%  
TIN ON FOOT AREA.

RECOMMENDED WORKING HEIGHT = 2.10mm / MIN FORCE = 1.2N  
RECOMMENDED MINIMUM WORKING HEIGHT = 1.70mm

**NOTES:**

1. QUANTITY PER REEL = 2500
2. ALL TOLERANCES ARE: X.X = ±0.30mm  
X.XX = ±0.15mm  
X.XXX = ±0.01mm  
ANGLES = ±5°  
UNLESS OTHERWISE STATED.

SB	4	07.03.12	11655
NAME	ISS.	DATE	C/NOTE
APPROVED: S.BENNETT			
CHECKED: S.FLOWER			
DRAWN: R.ADDE			
CUSTOMER REF.:			
ASSEMBLY DRG:			

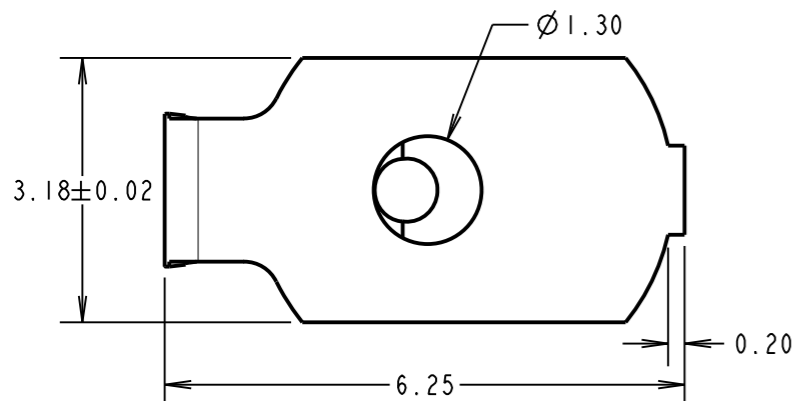

**HARWIN**  
www.harwin.com  
technical@harwin.com

THIS DRAWING AND ANY INFORMATION OR DESCRIPTIVE MATTER SET OUT HEREON ARE CONFIDENTIAL AND COPYRIGHT PROPERTY OF THE HARWIN GROUP AND MUST NOT BE DISCLOSED, LOANED, COPIED OR USED FOR MANUFACTURING, TENDERING OR FOR ANY OTHER PURPOSE WITHOUT THEIR WRITTEN PERMISSION.

**TOLERANCES**  
X = ±1mm  
X.X = ±0.25mm  
X.XX = ±0.10mm  
X.XXX = ±0.01mm  
ANGLES = ±5°  
UNLESS STATED

**MATERIAL:** SEE ABOVE  
**FINISH:** SEE ABOVE  
**S/AREA:** mm<sup>2</sup>

**TITLE:** SMT SHIELD FINGER (2.75mm) IN TAPE AND REEL  
**DRAWING NUMBER:** S7081-42R  
SHT 2 OF 2